

NOTES:

1. MATERIAL:
 - 1.1. HOUSING: PBT ,COLOR IS GRAY 537C;
 - 1.2. CONTACT: PHOSPHOR BRONZE, $\phi 0.46 \pm 0.02$ mm;
2. FINISH: PLATED GOLD OVER NI;
3. REFINISHED PCB THICKNESS: 1.60mm;
4. ELECTRICAL:
 - 4.1. VOLTAGE RATING: 125 VAC RMS;
 - 4.2. CURRENT RATING: 1.5 AMP;
 - 4.3. CONTACT RESISTANCE: 35MILLIOHMS MAX.;
 - 4.4. WITHSTAND VOLTAGE: 1000 VAC RMS 50(60)Hz,1MIN.;
 - 4.5. INSULATION RESISTANCE: 1000MEGOHMS MIN @500V DC;
5. MECHANICAL:
 - 5.1. MATING/UNMATING FORCE: 22N MAX.;
 - 5.2. RETENTION STRENGTH: 50N MIN.;
 - 5.3. OPERATING LIFE: 750 CYCLES MIN.;
6. SALT SPRAY TEST: 12H;
7. SOLDERABILITY: $245 \pm 5^{\circ}\text{C}, 5 \pm 0.5\text{S}$;
8. RESISTANCE TO SOLDER: $260 \pm 5^{\circ}\text{C}, 10 \pm 1\text{S}$;
- 9 ENVIRONMENTAL:
 - 9.1. STORAGE TEMPERATURE RANGE: $-40^{\circ}\text{C} \sim +85^{\circ}\text{C}$;
 - 9.2. OPERATION TEMPERATURE RANGE: $-25^{\circ}\text{C} \sim +70^{\circ}\text{C}$;
10. MATES WITH: MODULAR PLUGS THAT CONFORM TO FCC REGULATION PART 68.500;
11. THE MARK WITH "*" IS THE KEY INSPECTION DIMENSION FOR QC.

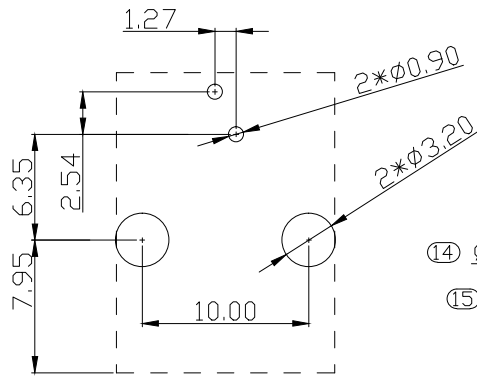

RECOMMENDED PCB LAYOUT
TOP VIEW(TOL:±0.05)

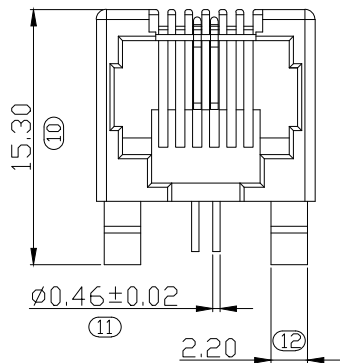
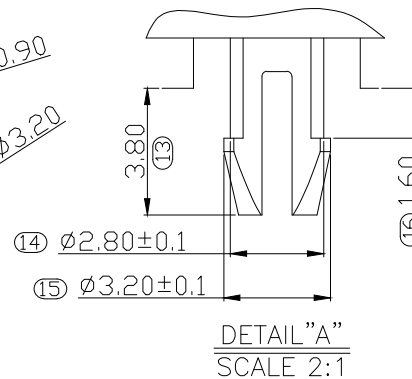

PART NO:
09.01.03.XXX

- 004: GRAY 537C
- 007: BLACK
- 013: GREEN

		new		2015/5/3	A	
ECN BO.		DESCRIPTION.		DATE.	REV.	
DESIGNED	CHECKED	APPROVAL	DRAWING NUMBER	SCALT: 1/2		SCALE: 3:1
Mikey	Tom	Jerry	PART NAME	11162WW02001	UNLESS OTHERWISE SPECIFIED, TOLERANCE:	X. ±0.25
			MODEL NAME	11162WW02001		X.x ±0.20
			3RD ANGLE PROJ	HANYONES TECH CO.,LTD		X.xx ±0.15
						ANGULAR ±3'
						FILE. NO.