

DETAIL C
SCALE: 8:1

NOTE:

- 1.MATERIAL:
HOUSING: THERMOPLASTIC HIGH TEMP WITH 40% GF, UL94V-0.
CONTACT: BRASS T=0.20mm
SHELL: STAINLESS T=0.50mm
- 2.FINISH:
CONTACT: GOLD PLATING ON CONTACT AREA,
MATTE TIN PLATING ON SOLDERTAILS
100u" MIN. NICKEL UNDERPLATING OVERALL.
SHELL: 50~90u" NICKEL PLATING OVERALL.
3. ▼ MAJOR DIMENSION. ▽ CRITICAL DIMENSION

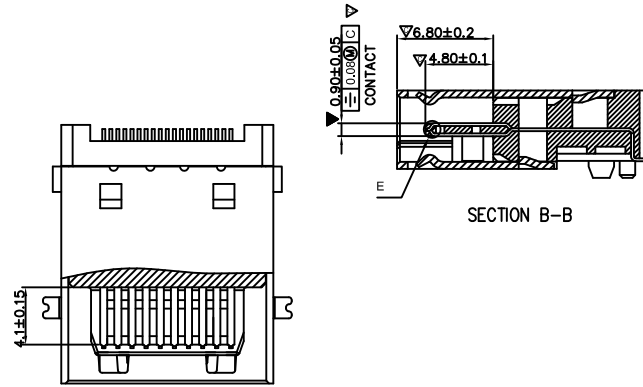
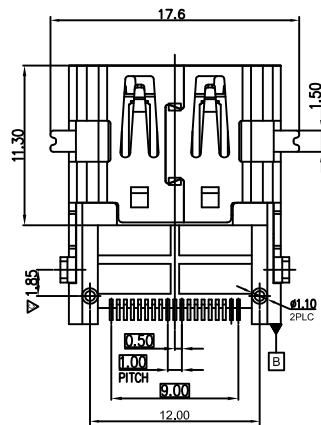
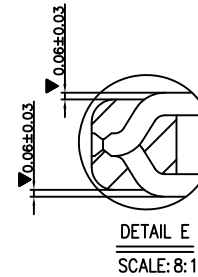
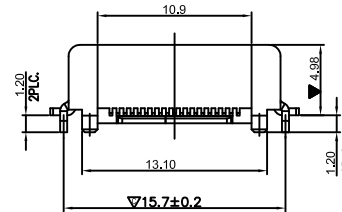
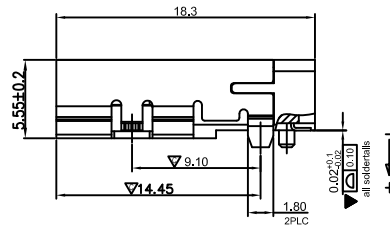
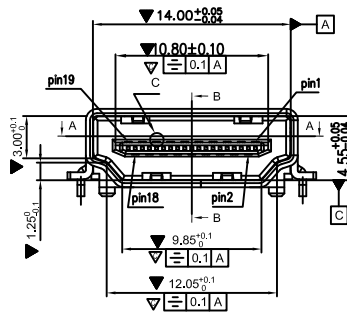

SECTION B-B

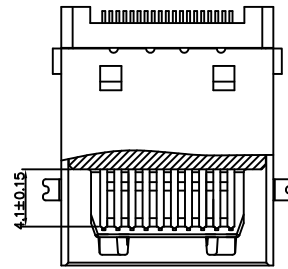

SECTION A-A

NO 번호	DATE 변경일자	DESCRIPTION OF REVISION 변경내용	DESIGNED 작성	CHECKED 검토	APPROVED 승인	MATERIAL 재질		SPECIFICATION 규격		FINISH 표면처리	QUANTITY 수량	SCALE 척도 UNIT 단위 / mm	
						DESIGNED 작성	CHECKED 검토	APPROVAL 승인	DRAWING NUMBER 도번				
			김도현	박재규	최귀환	PART NAME 부품명	HY-05H7	 한 유안 ELECTRONICS CO.,LTD					
						MODEL NAME 제품명	HY-05H7						
DESIGNED 작성						상현전자 주식회사		3RD ANGLE PROJ	HANYONES TECH CO.,LTD		FILE NO.		