

S:Scrolls

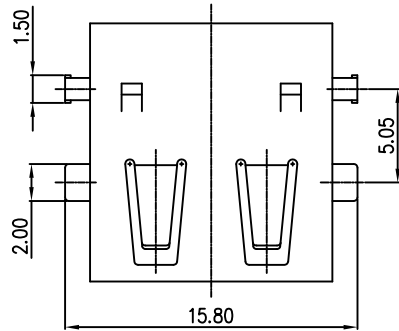

F:Flat

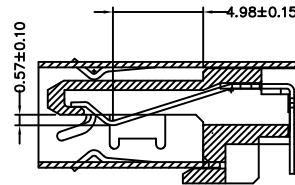

Housing Material: LCP 94V-0, black/White
 Contact Terminal: COPPER ALLOY. (T=0.25mm)
 Metallic Shell: SUS

FINISH:

- 2-1. CONTACT: UNDER PLATED 50u" MIN NICKEL ALL AREA.
 100u" MIN TIN IN SOLDER TAIL AREA.
 30u" MIN. GOLD PLATED AT CONTACT AREA.
- 2-2. SHELL: NICKEL 50u" MIN. PLATING OVERALL.

ENVIRONMENTAL CHARACTERISTICS:

- 3-1. OPERATION TEMPERATURE RANGE : -10°C TO +85°C.

NO 번호	DATE 변경일자	DESCRIPTION OF REVISION 변경내용	DESIGNED 작성	CHECKED 검토	APPROVED 승인	MATERIAL 재질		SPECIFICATION 규격		FINISH 표면처리	QUANTITY 수량	SCALE 척도 UNIT 단위	
						DESIGNED 작성	CHECKED 검토	APPROVAL 승인	DRAWING NUMBER 도번				
			김도현	박재규	최국호	PART NAME 부품명	HY-4BU02-X	 한유안 ELECTRONICS CO.,LTD					
						MODEL NAME 제품명	HY-4BU02-X						
DESIGNED 작성						상현전자 주식회사		3RD ANGLE PROJ	HANYONES TECH CO.,LTD		FILE NO.		