

Notes:

1. Dimension shall be interpreted per ASME Y14.5M1994.
2. Dimension marked ▽ & ▼ should be checked by Q.C. and process, engineers and ▽ should also check the CPK data.

Specification:

1. Current Rating: 2.0 AMP
2. Voltage Rating: 30V AC,DC
3. Dielectric Strength: 500V AC RMS for 1 minute.
4. Contact Resistance: 30 m Ω Max.
5. Insulator Resistance: 500M Ω Min. AT 250V DC.
6. Mating/Unmating cycles: 2000cycles
7. Temperature: -20°C to +60°C

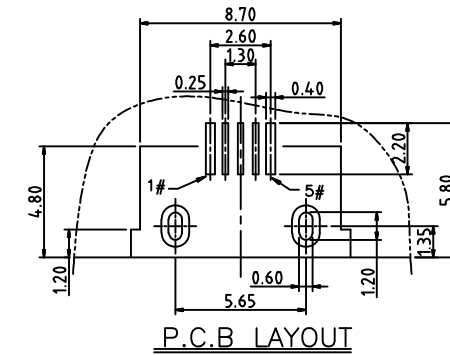

ITEM	PART NAME	Q' TY	FINISH	NOTE
3	Shell	1	SUS304R-1/2H Ni Plating T=0.30mm (3U)	
2	Contact	5	Phosphor bronze C5191R-EH Au/Ni Plating T=0.20mm (1U)	
1	Housing	1	PA9T&LCP (G.F30%)	

NO 번호	DATE 변경일자	DESCRIPTION OF REVISION 변경내용	DESIGNED 작성	CHECKED 검토	APPROVED 승인	MATERIAL 재질		SPECIFICATION 규격		FINISH 표면처리	QUANTITY 수량	SCALE 척도 UNIT 단위 / mm	
						DESIGNED 작성	CHECKED 검토	APPROVAL 승인	DRAWING NUMBER 도번				
			김도현	박재규	최국호	PART NAME 부품명	HY-M5SS-W-3		 한유안 ELECTRONICS CO.,LTD				
						MODEL NAME 제품명	HY-M5SS-W-3						
DESIGNED 작성						상현전자 주식회사		3RD ANGLE PROJ	HANYONES TECH CO.,LTD		FILE NO.		