

SECTION A-A

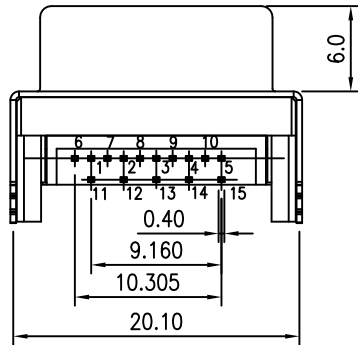
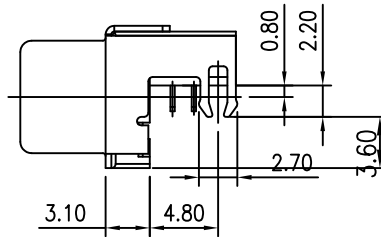
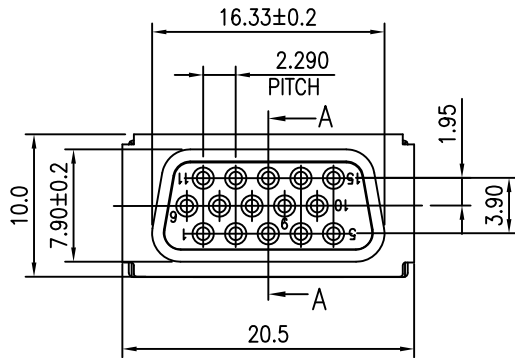

MATERIAL:

- Ⓐ HOUSING: THERMOPLASTIC, GLASS FIBER FILLED.  
UL 94V-0 RATED.
- Ⓑ SPACER: THERMOPLASTIC, GLASS FIBER FILLED.  
UL 94V-0 RATED.
- Ⓒ CONTACT: C5191R-H (t=0.30mm).
- Ⓓ FRONT SHIELD: SPCC (t=0.40mm).

FINISH:

CONTACT: UNDER PLATED 50u" MIN. NICKEL ALL  
OVER 100u" MIN. MATTE TIN IN SOLDERING  
AREA GOLD PLATED IN CONTACT AREA.  
FRONT SHIELD: NICKEL PLATED WITH 100u" THICK.

NO 번호	DATE 변경일자	DESCRIPTION OF REVISION 변경내용	DESIGNED 작성	CHECKED 검토	APPROVED 승인	MATERIAL 재질		SPECIFICATION 규격		FINISH 표면처리	QUANTITY 수량	SCALE 척도 UNIT 단위
						DESIGNED 작성	CHECKED 검토	APPROVAL 승인	DRAWING NUMBER 도번			mm
			김도현	박재규	최국호	PART NAME 부품명	HY02-15-X	 <b>한유안</b> ELECTRONICS CO.,LTD				
						MODEL NAME 제품명	HY02-15-X					
DESIGNED 작성						상현전자 주식회사		3RD ANGLE PROJ	HANYONES TECH CO.,LTD		FILE. NO.	